

T L Audio

User Manual

4/2 MIXER

Tony Larking Professional Sales Limited,

Letchworth, England.

Tel: 01462 490600. International +44 1462 490600.

Fax: 01462 490700. International +44 1462 490700

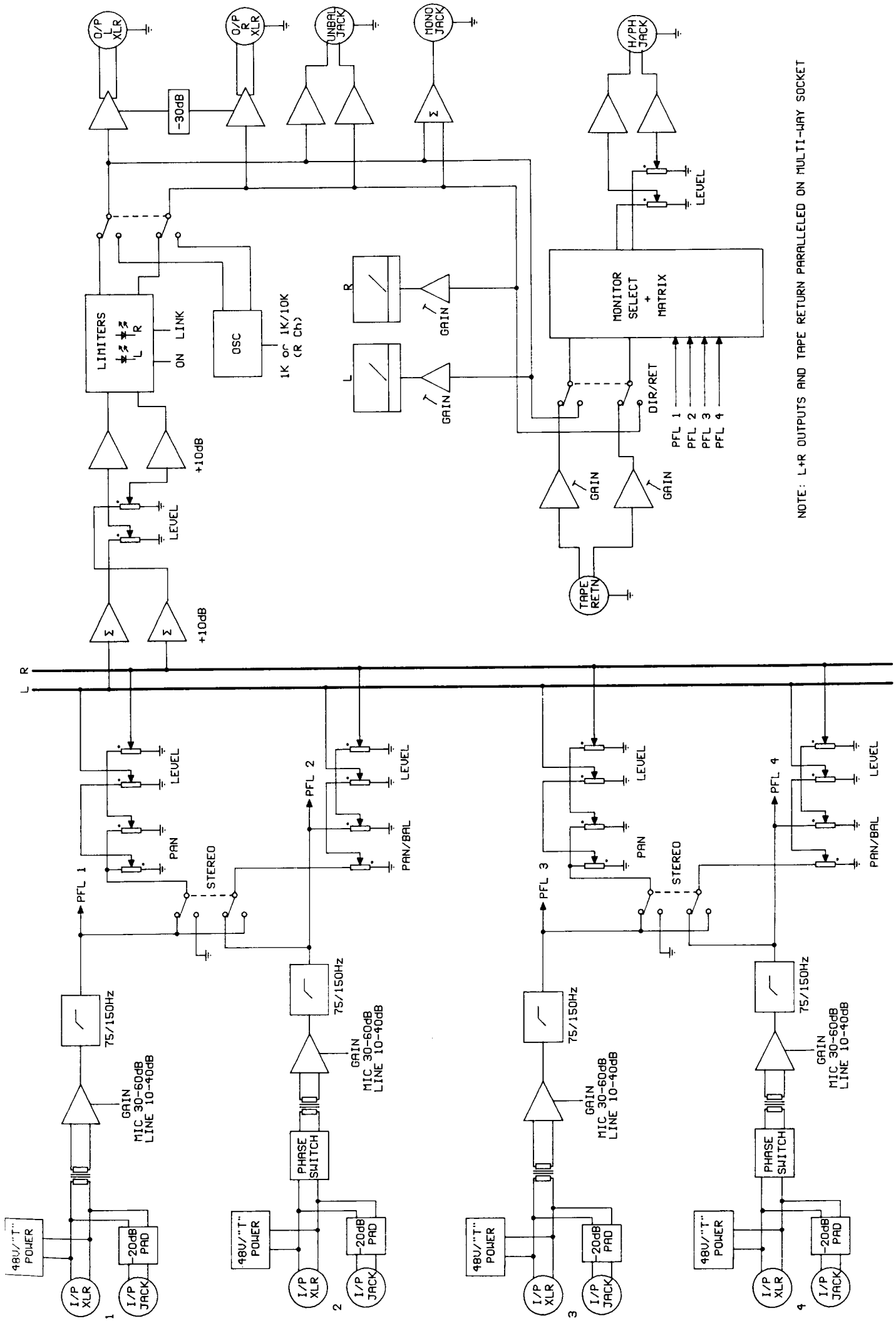

NOTE: L+R OUTPUTS AND TAPE RETURN PARALLELED ON MULTI-WAY SOCKET

TLA PORTABLE 4:2 MIXER AUDIO BLOCK DIAGRAM

CONTENTS.

1.	Introduction.....	3
2.	Inputs.....	3
2.1	General description.....	3
2.2	Connectors.....	3
2.3	48V phantom power.....	5
2.4	12V "T" power.....	5
2.5	Gain control.....	5
2.6	High pass filter.....	5
2.7	Phase reverse.....	7
2.8	Stereo inputs.....	7
3.	Level and Pan controls.....	7
3.1	Mono operation.....	7
3.2	Stereo operation.....	7
3.3	Master (output) level controls.....	8
4.	Limiters.....	8
4.1	Introduction.....	8
4.2	On/Off and Stereo linking.....	8
4.3	Threshold.....	8
5.	Outputs.....	10
5.1	Balanced outputs.....	10
5.2	-30dB pad.....	10
5.3	Unbalanced output.....	10
5.4	Mono output.....	10
5.5	Multi-way connector.....	10
6.	Monitoring.....	11
6.1	Monitor returns.....	11
6.2	Direct/Return switching.....	11
6.3	M-S Matrix.....	11
6.4	Selector switch.....	11
6.5	Mono checking.....	12
6.6	Output.....	12
7.	Oscillator.....	12
7.1	1KHz line up.....	12
7.2	1KHz/10KHz channel identification.....	12
7.3	Level adjustment.....	12

8.	Metering.....	12
8.1	VU.....	12
8.2	PPM.....	13
8.3	Adjustment.....	13
8.4	Illumination.....	13
9.	Power Supply.....	13
9.1	Overview.....	13
9.2	External DC supply.....	13
9.3	Battery operation.....	15
9.4	Re-chargeable batteries.....	15
9.5	Battery test switch.....	15
9.6	DC Out connector.....	16
10.	Maintenance.....	16
10.1	General care.....	16
10.2	Service.....	16
11.	Performance specification.....	17
	Block diagram.....	19

1. INTRODUCTION.

The TLA 4/2 is a portable mixer intended for any sound recording application where up to four microphone or line level inputs are to be combined into a stereo output. 48V phantom and 12V "T" powering is available, individually selected for each input. The input channels may be ganged for operation as stereo pairs.

The outputs are designed to interface at line or microphone level to cameras, radio transmitters, tape recorders, larger mixing consoles or power amplifiers, etc. Limiters are provided in the mix outputs, with switchable stereo linking. Typical uses are film and music recording, electronic news gathering (ENG), and live sound control.

Comprehensive monitoring is provided, including tape return inputs and sum + difference matrix decoding for use with stereo microphones. Monitoring output is via a type A stereo headphone jack socket. Models are available with VU or PPM metering.

The mixer may be powered by internal batteries, or from an external DC power supply. A DC power out connector allows other equipment to be easily powered from the external supply or switched internal supply of the mixer. All controls are recessed in a rugged, but lightweight metal case, with an optional carrying case available.

2. INPUTS.

2.1 General description.

The 4/2 mixer has four independent input channels. The inputs are floating, transformer isolated, to accept balanced or unbalanced low impedance microphones requiring input stage gain of between +10dB and +60dB. Optimum noise performance is achieved using 150-200 ohm impedance microphones. Balanced or unbalanced line level inputs are accepted via the combined XLR/jack socket, with a 20dB pad in the jack circuit.

2.2 Connectors.

The input connectors are combined 3 pin XLR/stereo jack sockets, which offer a compact means of interfacing at mic or line level.

Balanced connectors should be wired as:

XLR Pin 1 or Jack Plug Screen:	Ground (0V).
Pin 2 or Tip:	Signal phase (+).
Pin 3 or Ring:	Signal non-phase (-).

Connectors from unbalanced sources should be wired as:

XLR Pins 1 and 3 linked or Jack Plug Screen + Ring:	ground (0V).
XLR Pin 2 or Jack Plug Tip:	Signal phase (+).

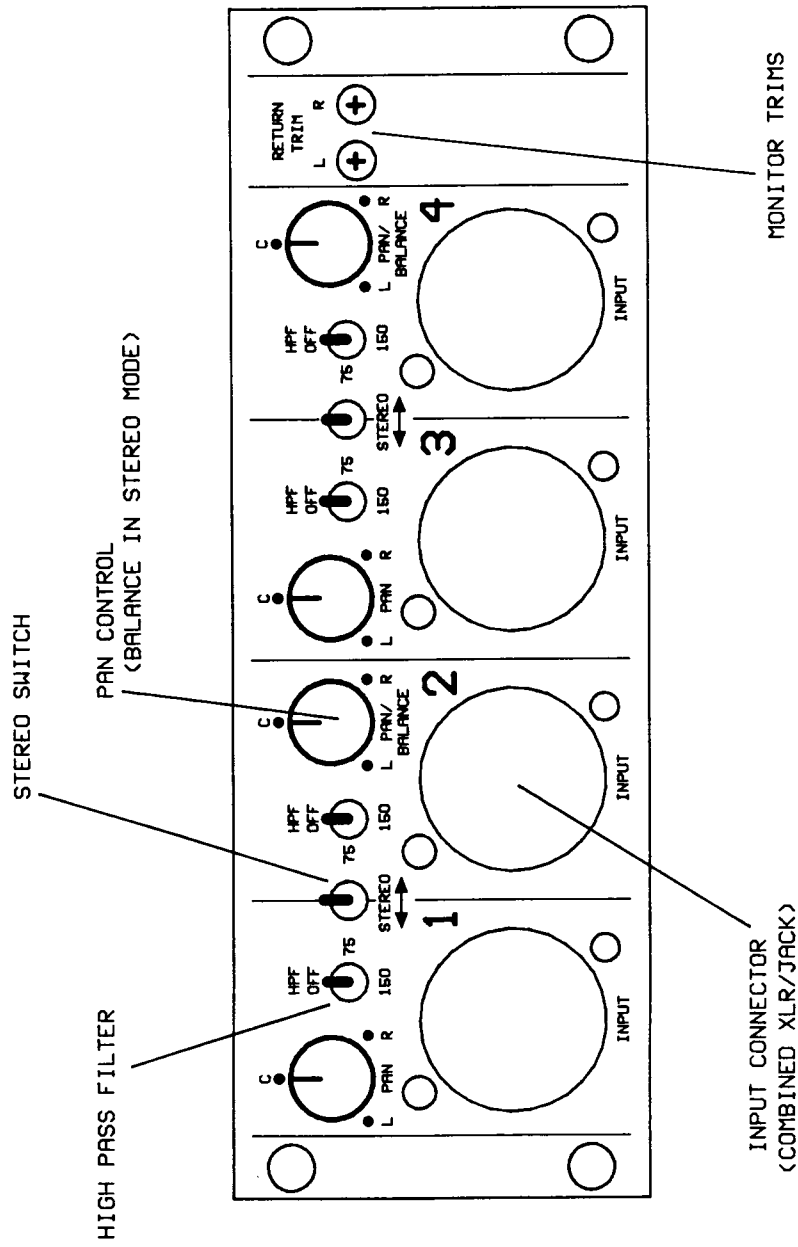

FIG. 1: INPUT PANEL

2.3 48V Phantom Power.

A three position switch on the front panel selects 48V or 12V "T" powering, with a centre off position (see fig. 2). In the PH position, +48V is applied to pins 2 and 3 of the input connector via 6K8 resistors. Phantom power should only be used with suitable, balanced, microphones. The current drain on the 48V supply from any one channel should not exceed 10mA.

2.4 12V "T" Power.

When the 3 position switch (see 2.3) is set to the "T" position, a low noise +12V supply is connected to pin 2 of the XLR via a resistor, and pin 3 is connected to 0V, also via a resistor. "T" power should only be used with suitable microphones, requiring not more than 10mA of current each.

2.5 Gain Control.

Each channel has a six position rotary gain control switch on the front panel (see fig. 2). Microphone gain is variable in 10dB steps from +10dB to +60dB, whilst the 20dB pad on the jack inputs provides overall line gain of -10dB to +40dB.

To obtain the optimum noise performance, the gain control should be set to obtain nominal output when the channel and output gain controls are operated around the 0dB gain position.

2.6 High Pass Filter.

A 2 pole, 12dB per octave, high pass filter is available on each input channel, selected by a 3 position switch above the XLR socket (see fig. 1). The switch allows the high pass filter to be off (i.e. flat response), or set to a corner frequency of 75Hz or 150Hz. The filter can be used to remove unwanted low frequencies such as traffic rumble or wind noise. The filter attenuation is shown in fig. 3.

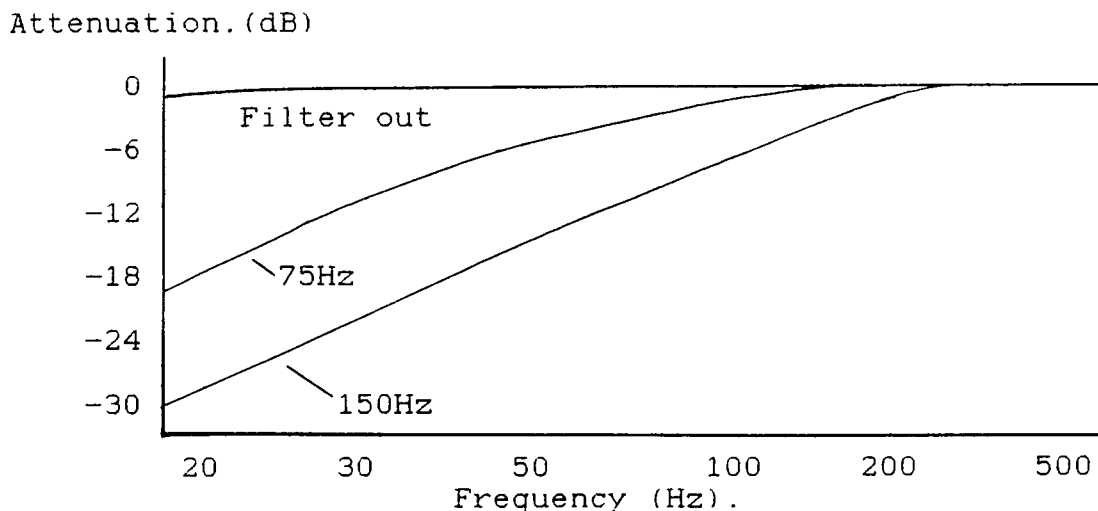

Fig. 3: High Pass Filter Response.

2.7 Phase Reverse.

Channels 2 and 4 are fitted with phase reverse switches, located on the front panel (see fig. 2). They are intended to compensate for a phase error due to wiring or microphone placement when using channels as stereo pairs. With most programme material, an out of phase signal on one leg of a stereo pair will appear to have reduced bass response which can be restored by setting phase reverse on the mixer. It is easy to compare the normal and phase reversed states to obtain the best response.

2.8 Stereo Inputs.

Input channels 1 and 2, and/or channels 3 and 4, may be paired for stereo operation. Stereo mode is selected by the toggle switches above the input connectors (see fig. 1).

In stereo mode, the left channel (1 or 3) is routed to the left output, and the right channel (2 or 4) is routed to the right output. The right channel pan control is converted into a balance control, and the level controls are ganged with the right channel controlling both legs. (see sections 3.2 and 3.3). The gain controls and filter switches continue to operate independently.

When using stereo microphones ("M-S" microphones), the M (or mid) signal should be connected to the left channel, and the S (side) signal to the right channel. These signals are decoded to conventional stereo by the monitoring circuit (see 6.3).

3. LEVEL AND PAN CONTROLS.

3.1 Mono Operation.

In mono or single channel mode, the level and pan controls operate conventionally. The level control (or fader) is situated above the gain control (see fig. 2), and is fitted with a winged knob for finger-tip operation of several controls at the same time. The 0dB position is clearly marked, and there is a further 10dB of gain in hand.

The pan control is situated above the input socket (see fig. 1), and pans the signal from fully left (anti-clockwise) through middle (centre) to fully right (clockwise).

3.2 Stereo Operation.

In stereo mode, the right channel pan control is converted into a balance control, with the left channel pan control having no effect. Also, the level controls are ganged, with the right channel controlling both legs, and the left channel level control having no effect.

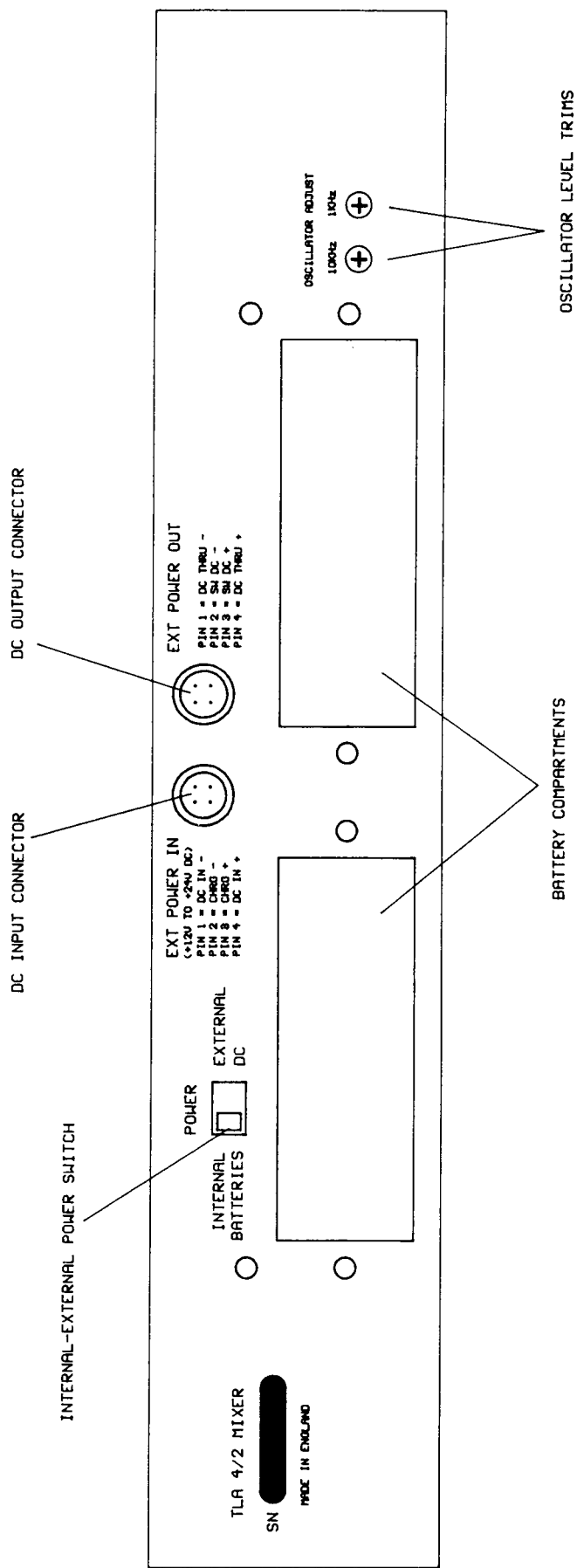

FIG. 5: REAR PANEL

3.3 Master (Output) Level Controls.

Separate left and right master controls are located to the right of the meters (see fig. 2), and are fitted with colour coded knobs matching the limiter warning LEDs. The controls have +10dB of gain in hand, with the nominal 0dB gain position marked.

These controls may be ganged for stereo operation, independently of the input channel mode, by the toggle switch above the right control. In stereo mode, the right control sets the gain of both legs with the left control having no effect.

4. LIMITERS.

4.1 Introduction.

It is often essential to prevent overloading equipment which the mixer outputs are feeding. For example, digital tape recorders can cause severe distortion, and broadcast transmitters have strict modulation limits. In order to maintain good signal to noise ratio and optimum working levels, a limiter must be included to control sudden or unexpected peaks in programme material.

The limiter in the TLA 4/2 mixer has a very fast attack time (less than 1 msec), essential for use with digital or transmission systems, and a slow release time, to maintain dynamic quality and smooth operation with no "breathing noises" or audible distortion at up to 20dB of overload. The limiters are positioned after the output level controls, to limit the output signal regardless of control settings. Two LEDs, colour coded to match the output master controls, indicate when the limiters are selected and gain reduction is occurring.

4.2 On/Off and Stereo Linking.

The limiters are placed in circuit by a toggle switch on the right hand side of the mixer (see fig. 4).

A second switch links the two limiters together for stereo ganging. In this mode, the gain of both output channels is reduced by the same amount whenever either channel exceeds the limiter threshold, thereby preserving the stereo image.

4.3 Threshold.

The limiter threshold is internally set to +8dBu (PPM 6) at the balanced output for the PPM meter option. Models with VU meters are adjusted such that a typical music signal limits at an average level of +4dBu (OVU).

Threshold adjustment should be referred to your dealer or a competent technician. It is necessary to remove the top cover, and adjust the preset controls RV1 (left) and RV2 (right).

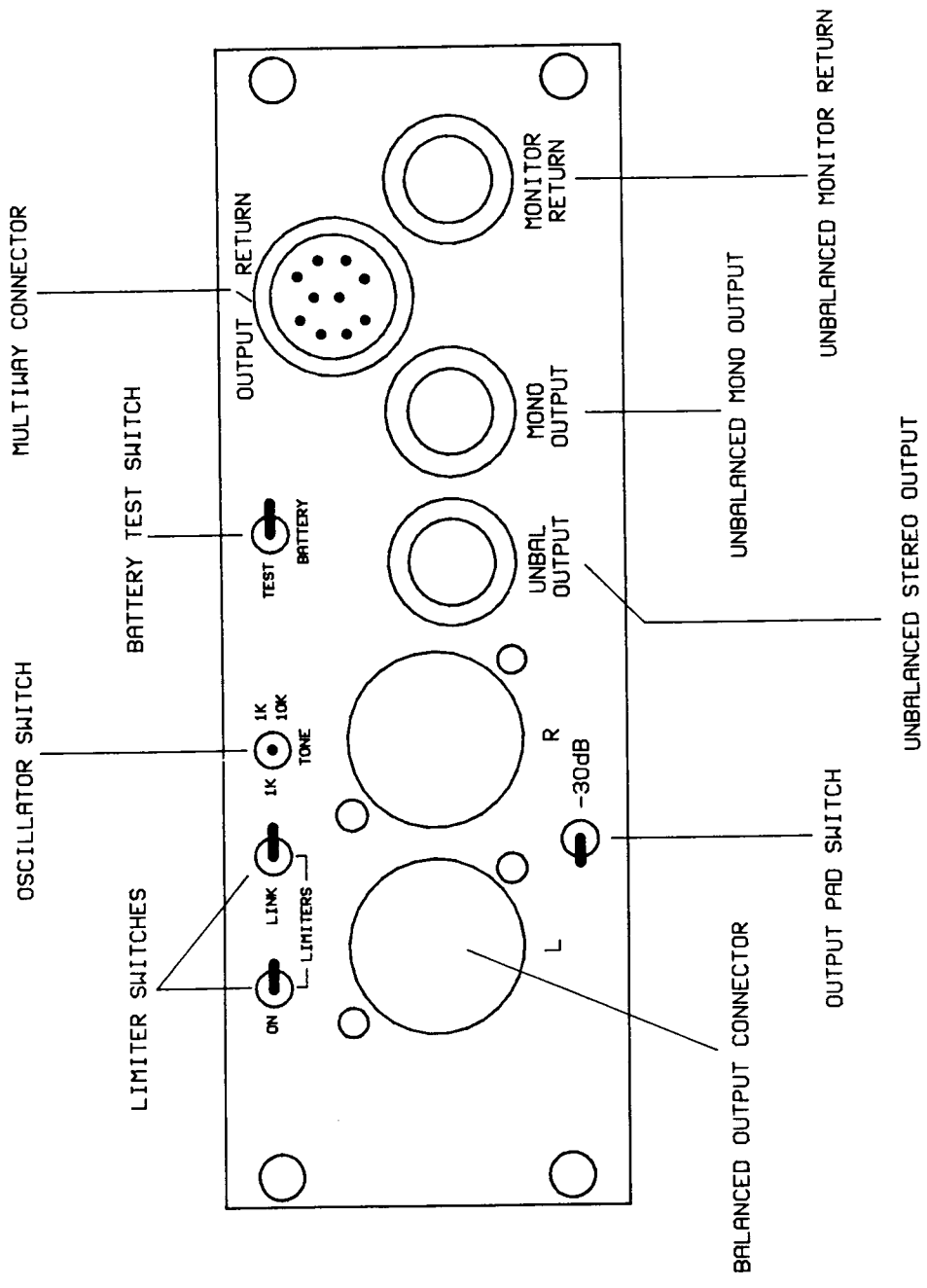

FIG. 4: OUTPUT PANEL

5. OUTPUTS.

5.1 Balanced Outputs.

The main outputs are via electronically balanced XLR connectors on the right side of the mixer (see fig. 4). Mating connectors should be wired as:

Pin 1: Ground (0V).
Pin 2: Signal phase (+).
Pin 3: Signal non-phase (-).

5.2 -30dB Pad.

The switch under the balanced output sockets allows 30dB of attenuation to be applied to the output stages of the mixer, making it compatible with microphone level inputs on tape recorders, etc. The meters and "direct" monitoring circuits take their feed before the pad.

5.3 Unbalanced Output.

A jack socket on the side of the mixer (fig. 4) carries an unbalanced stereo output signal, at a level 6dB lower than the balanced outputs and meter indication.

The socket is wired as:

Sleeve: Ground (0V).
Ring: Right channel phase (+).
Tip: Left channel phase (+).

5.4 Mono Output.

A mono output formed by summing the left and right output channels, is also available on a jack socket. It is an unbalanced signal at -3dB below the level of the stereo unbalanced output (see 5.3.). The connector is wired as:

Sleeve and Ring: Ground (0V).
Tip: Signal phase (+).

5.5 Multiway Connector.

A 10 pin "Hirose" type multiway connector is fitted to the right side of the mixer (see fig. 4), to facilitate rapid connection of outputs and monitor returns. All signals are balanced, but returns are suitable for use with unbalanced signals if the non-phase (-ve) is grounded. The pin numbers are shown below:

Ground (0V): Pins 9 and 10.

Left output: phase (+) pin 1, non-phase (-) pin 2.
Right output: phase (+) pin 3, non-phase (-) pin 4.

Left return: phase (+) pin 7, non-phase (-) pin 8.
Right return: phase (+) pin 5, non-phase (-) pin 6.

Wiring to the mating connector should use individual screened twisted pair cables or a multicore containing four pairs with an overall screen.

6. MONITORING.

6.1 Monitor returns.

Balanced tape return inputs are provided on the multiway connector (5.5.), plus an unbalanced stereo return on a jack socket (see fig. 4). The balanced and unbalanced signals are summed together at a gain trim stage. An adjustment of $\pm 10\text{dB}$ is available via preset controls, using a small screwdriver through holes in the left side panel of the mixer (see fig. 1).

The unbalanced returns are wired as:

Sleeve: Ground (0V).
Ring: Right signal phase (+).
Tip: Left signal phase (+).

6.2 Direct/Return Switching.

A switch on the front panel selects the direct outputs from the mixer or the tape returns as the signal source for the monitoring. As with any equipment, it is always advisable to monitor off-tape (returns) where possible, for confirmation that recording is actually taking place.

6.3 M-S Matrix.

The monitor signal is fed to a M-S decoding matrix, for conventional left-right stereo compatibility. The matrix generates the sum (S) and difference (D) signals, which are available for separate or combined monitoring as a stereo signal (S = left, D = right). The matrix outputs are available on the monitoring selector switch (6.4).

6.4 Selector Switch.

A rotary switch located on the front panel determines the signal fed to the monitor output. The signals available are:

Position 1: PFL channel 1.
2: PFL channel 2.
3: PFL channel 3.
4: PFL channel 4.
5: Stereo Left leg.
6: Stereo Right Leg.
7: Stereo L+R.
8: Matrix S+D,
9: Matrix S,
10: Matrix D.
11: Off,
12: Off.

The PFL signals are derived within the mixer, whilst positions 5 to 10 of the switch follow either the mixer DIRECT outputs or tape RETURNS.

.5 Mono Checking.

Checking for mono compatibility of a stereo signal is conveniently achieved using the S position of the selector switch.

.6 Output.

The monitoring output is via a type A stereo jack, suitable for low or high impedance headphones. (High impedance are recommended, to reduce battery drain). A rotary level control adjacent to the output socket controls the volume.

The output socket is wired as:

Sleeve: Ground (0V),
Ring: Right signal phase (+),
Tip: Left signal phase (+).

.7 OSCILLATOR.

.7.1 1KHz Line Up.

A three position "TONE" switch on the right hand side of the mixer sets the oscillator mode (see fig. 4). In the left position, "1KHz", a continuous 1KHz tone is fed to both left and right outputs, at a nominal level of +4dBu (0VU) or 0dBu (PPM4).

The oscillator is switched into circuit after the output level controls, allowing accurate calibration of subsequent equipment without the need to reset level controls on the mixer.

.7.2 1KHz/10KHz Channel Identification.

The right position of the TONE switch (7.2) routes continuous 1KHz tone to the left output, and alternating 1KHz and 10KHz to the right output, for on-tape identification in accordance with AES-EBU recommended practice.

.7.3 Level Adjustment.

The 1KHz and 10KHz oscillator levels may be adjusted with a small screwdriver, through the rear panel of the mixer (see fig. 5).

.8 METERING.

.8.1 VU option.

The VU meters are factory calibrated to read 0VU for +4dBu at the balanced output connector, with the pad switch out. The scale calibrations are from -20 to +3VU, with a secondary scale calibrated from 0 to 100%. See section 8.3 for calibration at other nominal levels.

8.2 PPM option.

PPM meters are factory calibrated in accordance with BS5428 part 9, to read PPM4 for 0dBu at the balanced output connector, but are adjustable over a +/-10dB range.

8.3 Adjustment.

The reference or line up position of the meters may be adjusted via the internal presets RV24 (left) and RV25 (right). These presets are located on the PCB above the output connectors, and the top cover must be removed to gain access. Any adjustment should be performed by a qualified technician.

8.4 Illumination.

A three position switch to the right of the meters switches on the internal illumination, continuously in the left position, or momentarily when held in the right position. Extended use of meter illumination obviously reduces battery life significantly.

9. POWER SUPPLY.

9.1 Overview.

The mixer may be powered by internal batteries or an external DC supply. The power supply unit is able to accommodate a wide range of input voltages, as the batteries discharge, or from the external supply. It is possible to operate the mixer from rechargeable cells, and to recharge whilst operating from an external supply. A suitable TLA mains PSU is available.

A separate DC out connector allows other equipment to be conveniently powered.

9.2 External DC Supply.

The external DC supply input socket is a "Hirose" 4 pin type, which supplies power to the mixer, with a separate charging circuit for suitable batteries. Only a DC supply with an output voltage between 12V and 24V may be used.

CAUTION:

Do not attempt to operate the mixer on any other type of supply.

The pin connection are as follows:

Pin 1: Mixer supply -.

Pin 2: Charge supply -.

Pin 3: Charge supply +.

Pin 4: Mixer supply +.

The mixer consumes between 100mA and 200mA from the external supply, depending on the phantom power drain, meter illumination use and headphone power output.

The slide switch on the rear panel (see fig. 5) controls the operation of the external supply. In the "EXTERNAL" position, the mixer will be powered from the external DC supply, whilst in the "INTERNAL" position, the mixer will operate from the internal batteries. The batteries should be recharged with the switch set to "EXTERNAL".

WARNING:

Do not attempt to recharge any batteries except those specifically intended for recharging, i.e. Nickel Cadmium types. Always follow the battery manufacturer's instructions.

9.3 Battery Operation.

The mixer is designed to operate on 8 "AA" size batteries. High capacity types are recommended, e.g. Duracell MN1500. The batteries are contained in two quick-change compartments on the rear panel, which are released by moving the side tabs in the direction of the arrows. When changing batteries, all 8 cells should be replaced at the same time. Expected battery life with dynamic microphones is approximately 12 hours, but will reduce if phantom powered microphones are used.

Remove the batteries from the mixer if it is not being used for any length of time.

9.4 Re-chargeable Batteries.

Rechargeable Nickel Cadmium AA size batteries may be used in place of Alkaline types. They provide a lower cost alternative to Alkaline types, but generally have a much lower capacity. Fully charged Ni-Cad batteries will typically power the mixer for 2 to 4 hours.

Refer to section 9.2 for charging instructions.

9.5 Battery Test.

The battery voltage may be read on the right channel meter, using the TEST switch on the right side of the mixer (see fig. 4). With the VU option, the indication is on the % scale: 100% is the reading for new batteries, with operation possible down to 60%, although most batteries will discharge quickly below a reading of 70%. The PPM option has a specially screened battery test bar, indicating the acceptable voltage range.

Setting the TEST switch has no other effect on the mixer, and may be used at any time during operation.

9.6 DC Out connector.

A separate DC output connector is provided, as a convenient means of powering auxiliary equipment. Two circuits are provided: a through link of the external battery (unswitched), and the switched mixer supply.

The switched mixer supply is derived either from the external supply, or from the internal batteries, depending on the position of the rear panel slide switch.

The current drawn from the switched supply should not exceed 200mA. When operating from batteries the life will, of course, be reduced according to the additional power used.

The connector pin numbers are as follows:

Pin 1: External supply through -.

Pin 2: Switched DC -.

Pin 3: Switched DC +.

Pin 4: External supply through +.

10. MAINTENANCE.

10.1 General Care.

The TLA 4/2 Mixer has been constructed to high standards of electronic and mechanical engineering, but like all equipment it will benefit from a little consideration. The optional carrying case is recommended for mixers which will be used outside for long periods.

The mixer should never be immersed in liquid, or have any liquid poured over it. Should this happen, the mixer must be allowed to dry out thoroughly and then be inspected by a technician before being switched on. Prolonged use or storage in damp, dusty or corrosive environments, and at extremes of temperature should also be avoided.

Apart from the batteries, there are no user serviceable parts inside the mixer. The top and bottom covers should only be removed by a qualified technician, in a clean environment. Do not operate the mixer with any part of the case removed, or with any damaged control or connector.

10.2 Service.

Should the mixer require service, it should be returned to your dealer. It is advisable to retain the original packing to avoid damage in transit, which remains the responsibility of the sender. Please remember to include a detailed description of any suspected fault, and keep a record of the serial number.

11. PERFORMANCE SPECIFICATION.

Inputs

Four channels. via combined XLR/Jack socket with 20dB pad on jack and floating transformer isolation.

Accept balanced or unbalanced microphones and line inputs requiring -10dB to +60dB of gain.

Individually switchable 48V phantom power and 12V "T" power.

Switchable High Pass filter. 12dB per octave. -3dB @ 75Hz or 150Hz.

Maximum gain

80dB. channel and output level controls at maximum.

Sensitivity

250uV. gain 60dB. channel level at maximum. output level at 0dB.

Maximum input level

Microphone @ +10dB gain: +6dBu (1.55V rms).

Line level @ -10dB overall gain: +26dBu (15.5V rms).

Noise

-127dBu EIN (equivalent input noise) @ 60dB gain. 200 ohm source impedance. 20Hz to 20KHz (XLR input).

Frequency Response

20Hz to 20KHz. +0,-1dB (XLR input).

Crosstalk

-80dB. channel to channel @ 1kHz.

-65dB. channel to channel @ 15KHz.

Stereo Operation

Channel 1+2 and 3+4 switchable for stereo. with ganged level control and pan control converted to balance.

Separate stereo switch to gang master (output) level control.

Phase Reverse

Switchable on channels 2 and 4.

Limiters

Switchable limiters with Stereo link switch.

Dual LEDs. colour matched to output level controls. indicate when gain reduction occurring.

Attack time 1msec. release time 0.1sec.

Threshold +8dBu (PPM 6).

Outputs

Electronically balanced on 3 pin XLR connectors. duplicated on multiway connector. Maximum level +20dBu.
-30dB pad switch to match output to low level inputs.
Unbalanced stereo output via 1/4" jack.
Unbalanced mono output via 1/4" jack.

Oscillator

Continuous 1KHz tone into both output channels. or 1KHz to left channel and alternating 1KHz/10KHz to right channel for identification.
Level adjustment by preset through rear panel.

Metering

Dual PPM meters, calibrated to PPM4 = 0dBu on balanced outputs. or dual VU meters calibrated to 0VU = +4dBu on balanced outputs. Nominal levels internally adjustable +/-10dB.
On-off-momentary illumination switch.
Test switch indicates battery voltage on right meter.

Monitoring

Balanced tape returns via multiway connector. plus unbalanced returns on 1/4" jack. Gain trim controls adjusted through side panel.
Switch to select direct outputs or tape returns to monitor circuit.
Matrix to decode M-S to stereo. and to check phase and mono compatibility.
Input channels available individually for PFL.
Level control and 1/4" jack output suitable for high or low impedance headphones.

Power Supply

External DC supply, +12V to +24V @ 200mA. or internal alkaline or rechargeable batteries. Batteries may be recharged from the external supply whilst mixer in use.
Battery operation down to 9V combined voltage.
Typical battery life with dynamic microphones 12 hours.

Dimensions

315mm wide x 180mm deep x 58mm high overall. all controls and connectors recessed.

Weight

2.8Kg including batteries.

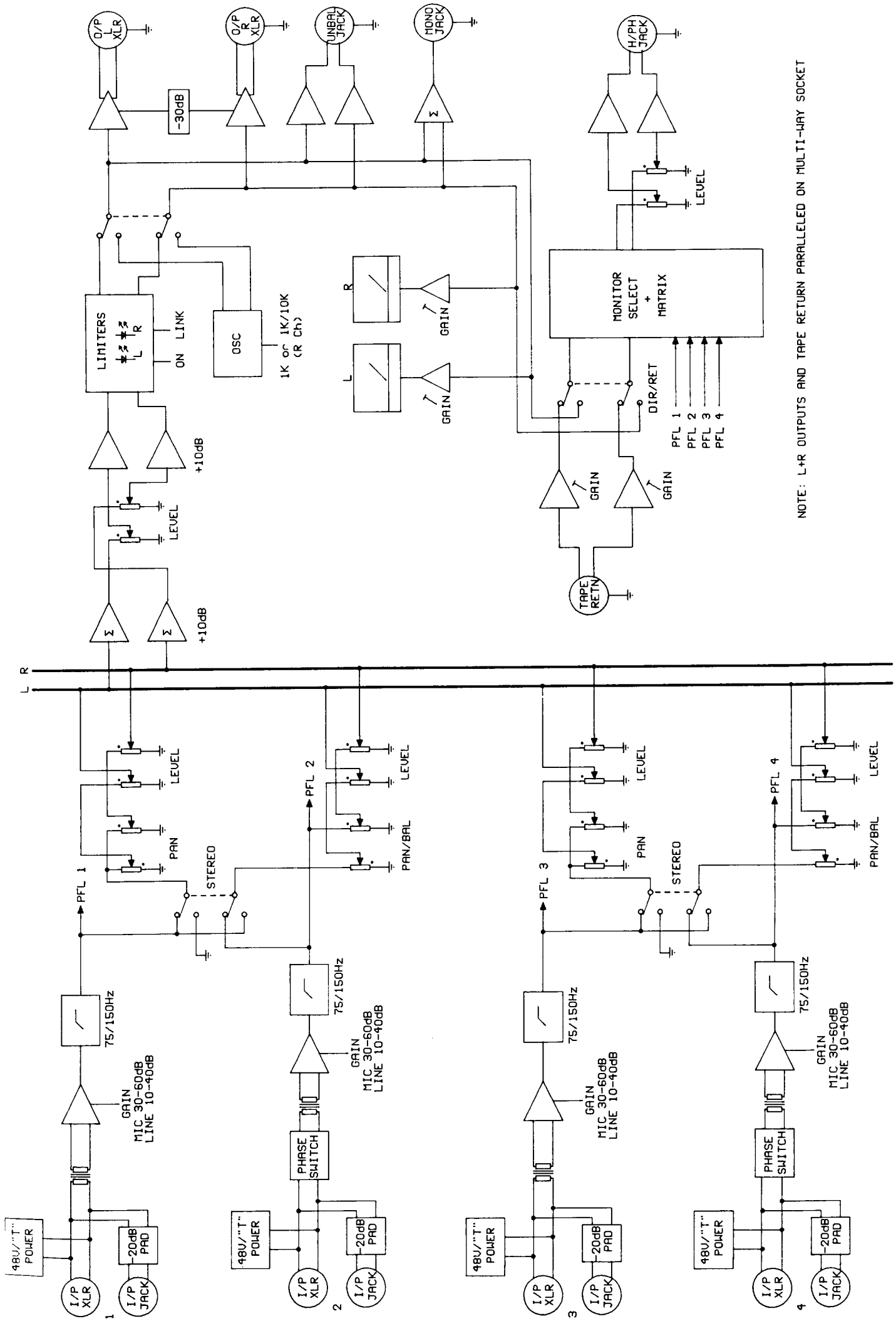

NOTE: L+R OUTPUTS AND TAPE RETURN PARALLELED ON MULTI-WAY SOCKET

TLA PORTABLE 4:2 MIXER AUDIO BLOCK DIAGRAM